



Starplast® 

SYSTEMS
THAT CHANGE THE
FUTURE

inPLUVIO®
Drain Blocs



technical and commercial catalogue 01/2025



**LAND DEFENCE
SYSTEMS AGAINST
HYDRAULIC AND
HYDROLOGICAL
RISK**



**Drainage Bloc system made of injection-moulded polypropylene (PP) with high mechanical strength.
Used for urban drainage and the management of large volumes of storm water.**

THE PROBLEM

Severe climate change and the massive overbuilding of our territory in recent years have highlighted the inadequacy of rainwater regimentation networks, dramatically increasing the hydraulic and hydrological risk throughout our territory.

THE SOLUTION

Starplast has come up with the **InPluvio** system, a definite answer to the problem of road flooding and river overflows, thanks to its drainage system.

APPLICATIONS

InPluvio system is suitable with every need of underground accumulation of water, i.e. releasing in a controlled way into the environment, without stealing space from urban areas, thus keeping availability of the land above.

THE CYCLE OF WATER

Is essential for the proper distribution of water on Earth and for the life of living beings.

It consists of of different phases:

Process by which water absorbed from the soil is released into the atmosphere by plants in the form of water vapour.

Water in oceans, lakes and rivers is transformed into steam by the heat of the sun.

Water vapour cools down and forms clouds.

Water flowing on the surface until back into the seas and rivers.

Water falls to the ground in the form of rain, snow or hail.

Water infiltrating the ground and feeding the aquifers.

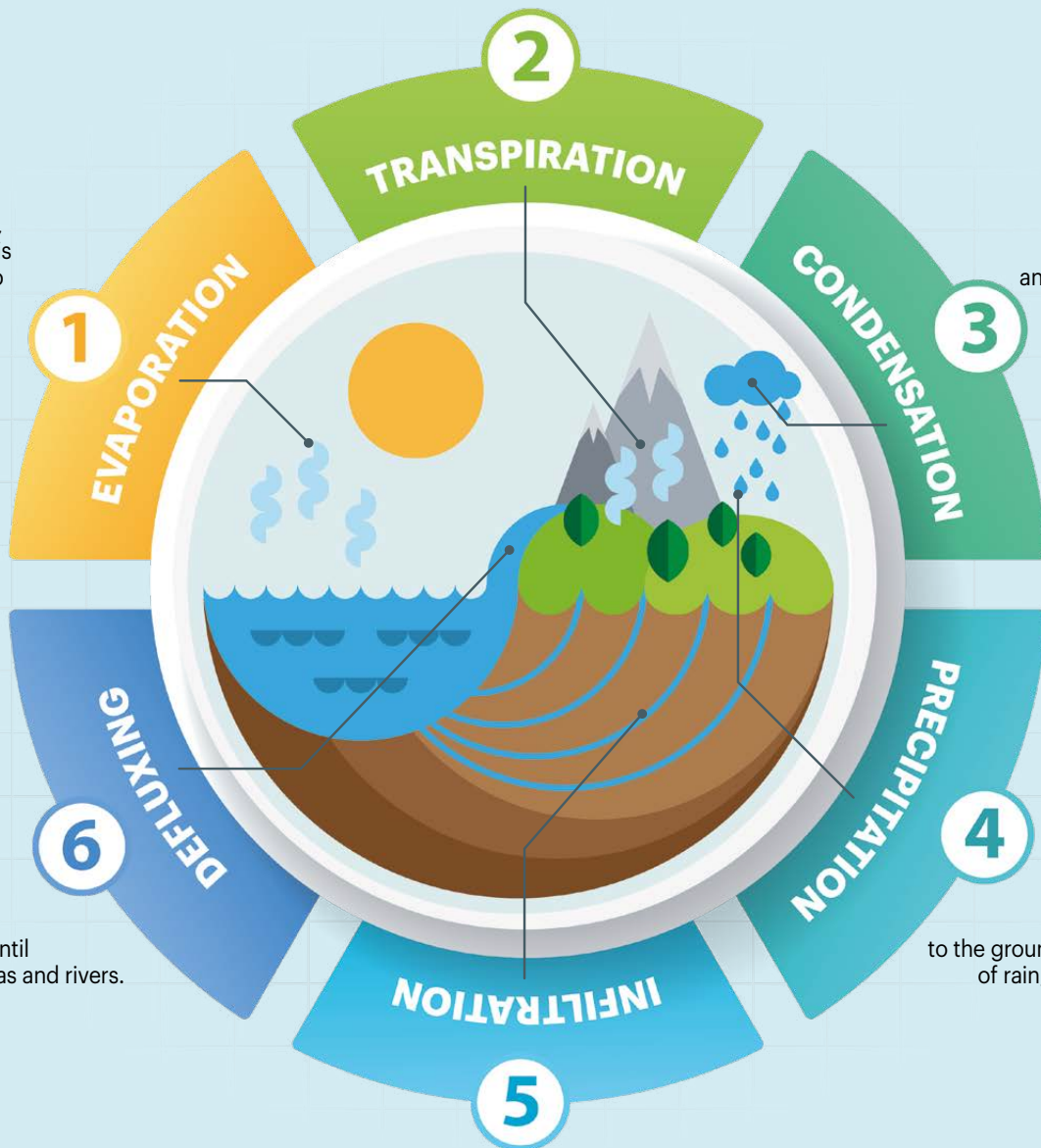

DROUGHTS AND FLOODS

CLIMATE CHANGE

Droughts and floods are two extreme phenomena linked to the water cycle that are becoming more frequent and intense due to climate change and human activity.

Rainfall shortages and rising temperatures lead to a drying up of water reserves, with devastating consequences for the environment and human activities.

Floods, on the other hand, are caused by violent and heavy rainfall, which can swell rivers until they overflow, destroying infrastructure, contaminating water and endangering people's safety.



URBANISATION

The strong growth of global urbanisation has led to a change in the natural course and management of water.

Water is being lost due to leaks in water networks and especially due to the dramatic increase in surface runoff, often with negative impacts on water supply and quality.

The principles of **hydraulic and hydrological invariance** arise as a response to these problems and their consequences for stormwater management.

The objective of these principles **is to reduce the impact of land modifications on the natural dynamics of water runoff**, preventing flooding, soil erosion and environmental degradation.



THE PROBLEM

URBANISATION AND DROUGHT

To counteract the effects of climate change and urbanisation, it is essential to adopt **innovative solutions** such as drainage cells.

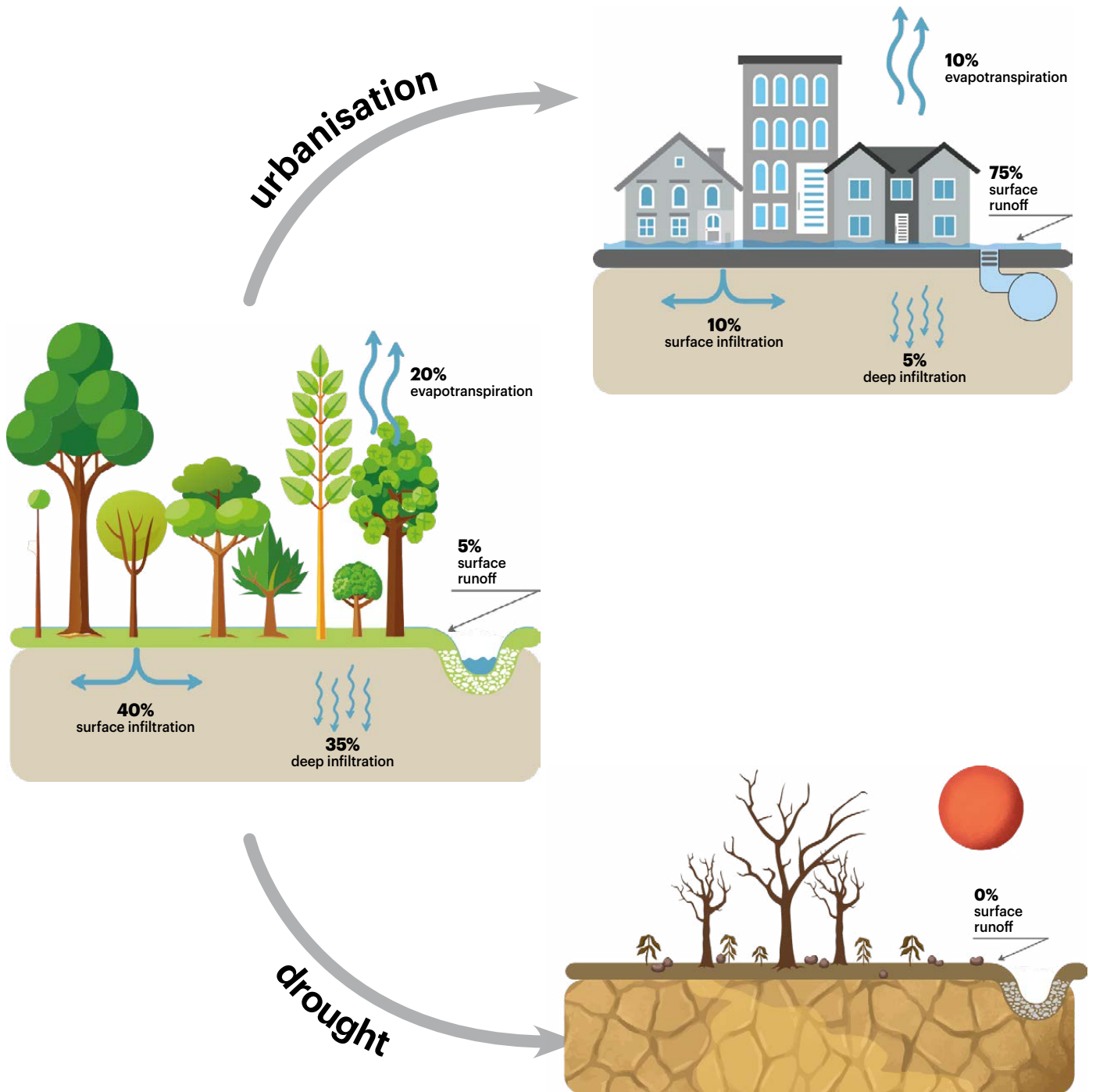

solution with inPluvio

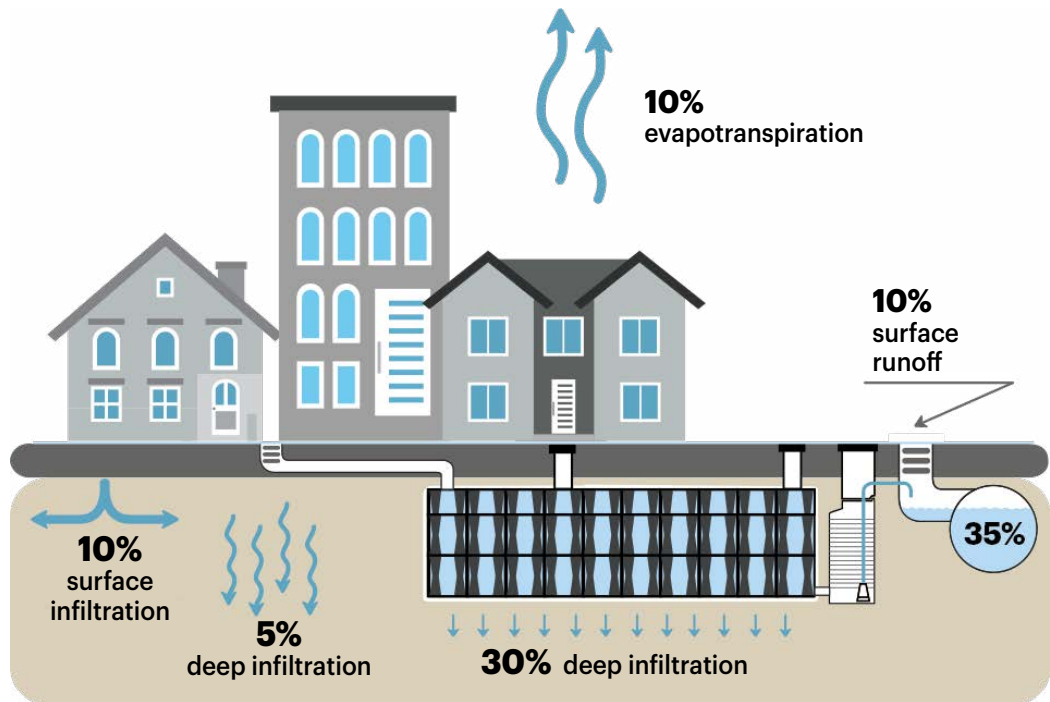

solution with inPluvio

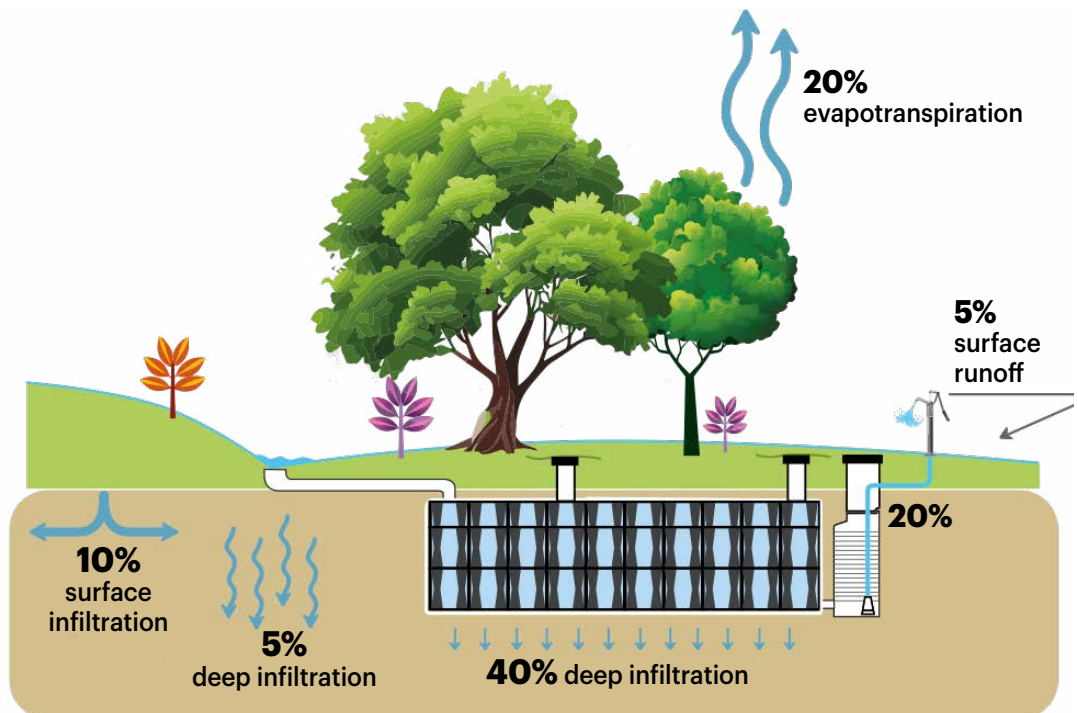

THE SOLUTION



Starplast designs and manufactures its new sustainable urban drainage cell system. Innovative, modern and durable, it enables the management of large volumes of rainwater, with the aim of:

- RECHARGE AQUIFERS
- PREVENTING FLOODING
- SUPPORTING VEGETATION
- URBAN SUSTAINABILITY

inPLUVIO®

Drain Blocs

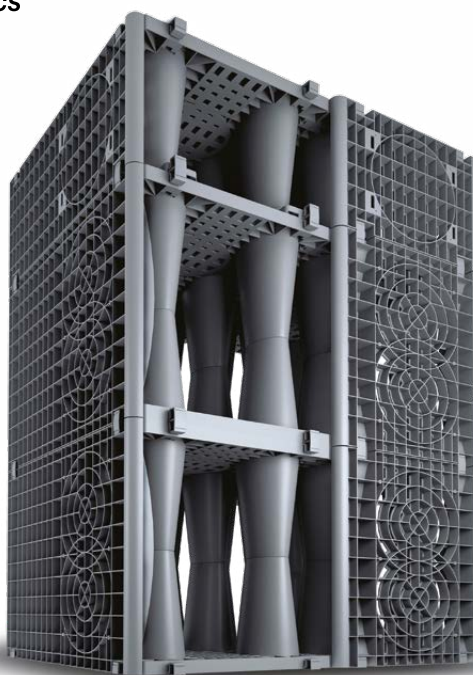

inPLUVIO joins the wide range of Starplast products, whose mission is sustainability and the protection of our most precious asset: **water.**

inPLUVIO is a system of drainage blocs, made of injection-moulded polypropylene (PP), with high mechanical resistance.

The system consists of two stackable elements (for optimised transport) which, when joined together, form the single module with dimensions of: 1,000 x 600 x h720 mm, with a volume of 0.42 m³. The assembly of the various modules, joined by the anchorages and side walls, allows the construction of an underground system of various volumes for multiple applications.

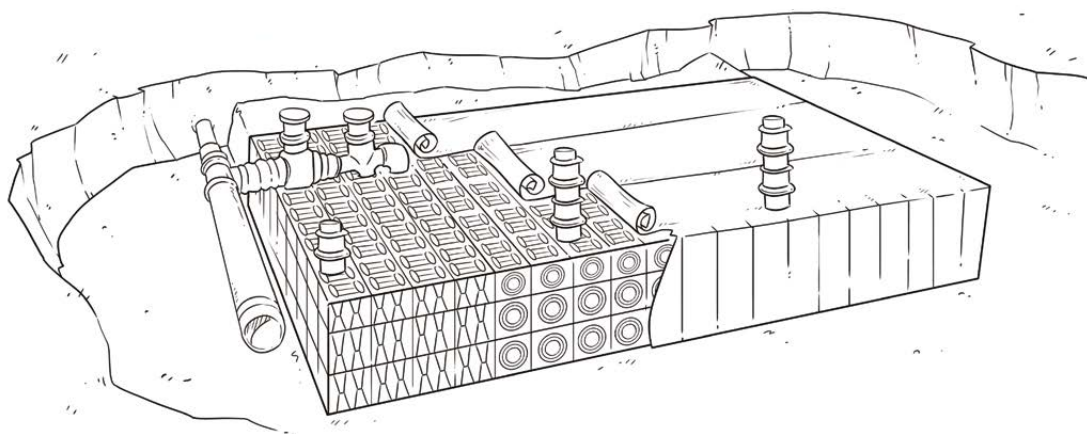

THE SOLUTION

FOR THE CORRECT IMPLEMENTATION OF THE SYSTEM

HYDRAULIC DIMENSIONING

The volume to be drained, i.e. the volume used for drainage, lamination and storage, is a function of the draining surface area and the type of surface area, which may be more or less permeable. Car parks for buildings or commercial structures, building roofs, industrial areas, roads, etc. can be drained.

The maximum rainfall must also be taken into account, with which the volume of the system must be sized according to the area where the system is to be located. In some cases, as already mentioned, volumes are provided by the Managing Authorities/Municipalities/Regions which, depending on the level of hydraulic risk, area surfaces, provide the system volumes or calculation models to be carried out. It is therefore advisable to always consult the existing regulations in advance. If the water is to be drained into the water table, the geological characterisation of the ground is essential (permeability, maximum submergence of the water table, etc.).

The most common calculation methods are:

MINIMUM REQUIREMENTS METHOD

The method is based on values of the minimum reservoir volumes imposed by regulations by the managing bodies of a volume W_{ssl} [mc/ha] and a limiting discharge rate $Q_{u, lim}$ [l/s x ha].

The volume of the reservoir must then be related to the surface area of the drained area and the type of drained areas (average runoff coefficient).

RAINFALL-ONLY METHOD

The rainfall-only method provides an assessment of the flood volume of the mitigation structure based solely on knowledge of the rainfall possibility curve and the maximum flow rate, assumed to be constant, that is desired at the outlet of the structure itself ($Q_{u, lim}$).

With this method, with the exception of hydrological losses, the inflow-deflow transformation that takes place in the draining area upstream of the work is completely neglected.

With this simplifying assumption, the volume entering the reservoir (W_e) is calculated due to a rainfall duration (d).

01 TOTAL VOLUME

It is important to define the volume of the system in accordance with the informative provisions of the regulations of the region in which the system is installed, respecting the following conditions:

Lu (longitudinal) multiples of 1000mm

La (lateral) multiples of 600mm

Lu > La

minimum h (no. 1 cell) 720 mm

maximum h (no. 7 cells + no. 1 half-cell)

5440 mm*

* please check with Starplas technical office.

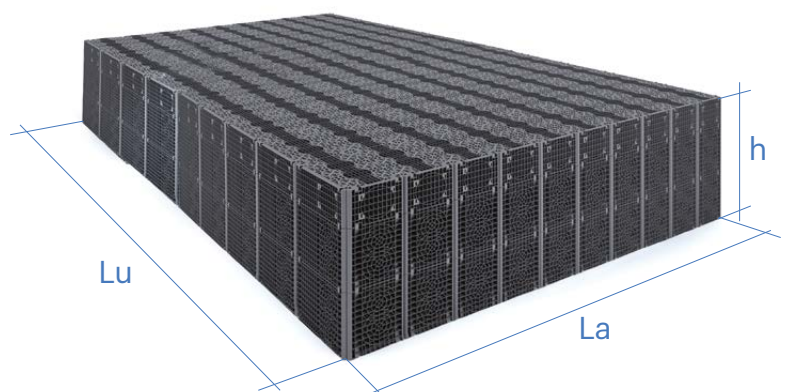

After having correctly dimensioned the volume of the drainage/lamination basin, it is necessary to proceed with the other operations described below.

02 PRE-TREATMENTS

Assessing the origin and quality of the water to be recycle in the basin by providing the appropriate pre-treatment facilities:

- sandy soils (provide sand separator)
- oil/hydrocarbon pollutants (envisage continuous de-aerator)
- other types of pollutants (to be designed)



03 PIPING

Size the inlet piping to the basin by inserting specific manifolds, separating the inlets in such a way that the water flow is divided equally within the drainage system.



04 BASKET

If pre-treatment (02), is not foreseen, define the water inlet points by inserting special stainless steel grids inside the inspection pit, which have the function of retaining coarse matter.



05 INSPECTION POINTS

In order to ensure better inspection and maintenance of the system, it is recommended to place 1 inspection pit every 3 rows alternately and opposite each other on the **La** side (multiples of 600 mm) of the system.

They are required for cleaning the drainage basin by means of pressurised water jets and suction of deposited sludge.

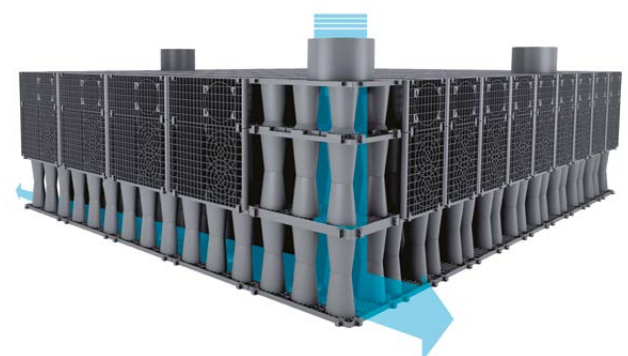

THE SOLUTION

FOR THE CORRECT IMPLEMENTATION OF THE SYSTEM

06 WATER DRAINAGE SYSTEMS FROM THE BASIN

Evacuation systems with drainage cells promote controlled water runoff, preventing flooding and sewer overflows. These modular structures gradually store and release water, improving hydraulic and environmental management.

The solutions are:

- 06.1 *Drainage in the water table with geotextile only*
- 06.2 *Mixed: groundwater drainage with calibrated pipe and geotextile fabric*
- 06.3 *Sub-basement outlet with geomembrane and calibrated pipe*
- 06.4 *Sub-slope outlet with pump inside the system or outside with tank*

06.1

DRAINAGE SYSTEM

in the case of hydrological invariance

Cell system entirely **wrapped with geotextile** that collects rainwater and returns it to the receiving water bodies (rivers, aquifer) in a controlled manner, providing for its regimentation in order to:

- ✓ optimise groundwater recharge
- manage overflow reservoirs where water
- ✓ can be controlled and drained in areas away from receptors

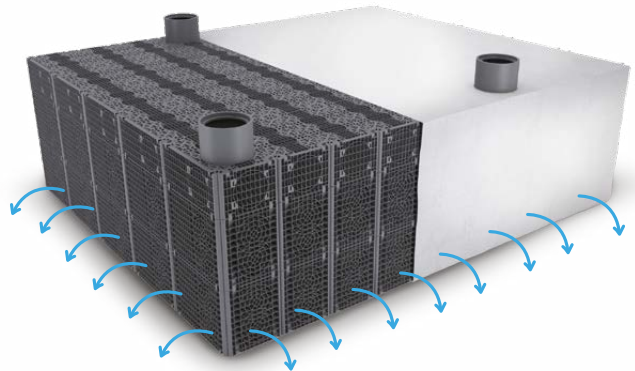

06.2

MIXED SYSTEM

infiltration and lamination

If there is a need to ensure drainage on ground with poor permeability and at the same time to send excess water at a controlled flow rate to the receptor, it is possible to equip **inPLUVIO** completely wrapped with geotextile and calibrated pipe.

In this case, controlled flow rate outflow through the calibrated pipe or lift pump to the surface watercourse/ sewer will be guaranteed and at the same time permeability to the soil will be ensured.

- ✓ minimum maintenance of groundwater recharge
- ✓ controlled outflow to the watercourse, avoiding the risk of flooding

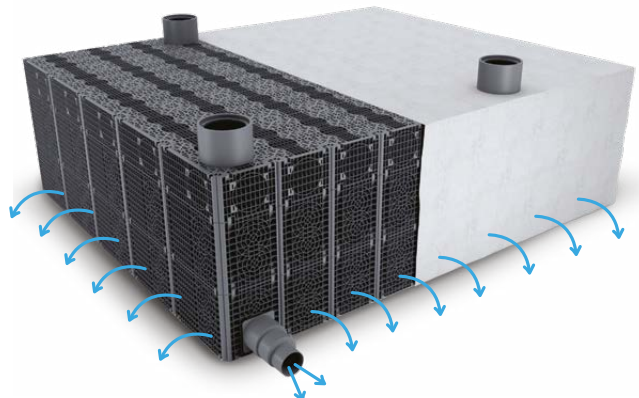

06.3

LAMINATION BASINS for hydraulically invariant storage systems

If the subsoil is not suitable for infiltration, it is advisable to accumulate the water and subsequently release it into the receptor bodies by discharging it over time, using the in**PLUVIO**, system, completely wrapped first with geotextile, then with HDPE **geomembrane** and externally again with geotextile.

Rainwater spreads evenly inside the cells, where it is temporarily collected and subsequently released in a regulated manner with a calibrated pipe, possibly with motorised valve or lifting pump.

The system in**PLUVIO**, intended for storage and lamination, must be sealed, impermeable and watertight in order to:

- ✓ reduce the size of the drained networks
- ✓ time management of runoff generated by heavy rainfall



06.4

WATER RECOVERY AND REUSE where there is a need to recover and reuse rainwater

Water is a precious resource that must be used carefully, avoiding waste and abuse.

Depending on the need, it may be more cost-effective to collect, store and reuse rainwater instead of allowing it to seep into the ground or direct it into the sewerage system.

Collected water can be reused for:

- ✓ irrigation purposes:
 - intensive agriculture
 - gardens and green areas
- ✓ recovery of non-potable industrial use or washing car parks/roadways



THE SOLUTION

OTHER IMPORTANT ASPECTS OF THE SYSTEM



EASE OF TRANSPORT

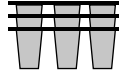

in**PLUVIO** allows the construction of large reservoirs at a low transport cost:

- Stackable together, one truck transports up to 550 m³ volume of drainage cells
- Reduced transport with lower of CO₂ emissions
- Reduction of storage space in retail warehouses



RAPID LAYING ON SITE

With smart docking systems, the system is easy and quick to install, thus reducing the time required for installation.



LARGE VOLUMETRY

The in**PLUVIO** system guarantees a usable volume of 96% of the total footprint.

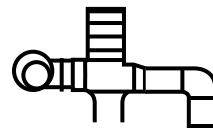

ACCESSORIES

Build the entire system thanks to countless accessories such as:

- water inlet/outlet couplings
- distribution manifolds
- coarse/plastic inlet grids
- inspection ports for chimneys
- manholes with various types load class A15, B125, C250, D400.



LIGHTNESS

The in**PLUVIO** system is easy and quick to position thanks to the low weight of the elements (the single element weighs less than 9.5 kg).

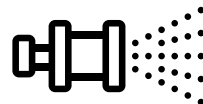

SIMPLE MAINTENANCE

The in**PLUVIO** basin is easy to inspect with video inspection systems and simple to clean with a water jet and sludge suction, thanks to the layout of the hatches distributed as per the design.

In fact, thanks to pre-drilled cell modules, it is possible to realise inspectable chimneys without additional costs, while maintaining the mechanical resistance necessary for the system.

A number of accessories are available for simple maintenance that can also be carried out independently without the help of specialised companies.



RESISTANCE

The in**PLUVIO** system guarantees the possibility of using the surface above the accumulation for different situations, from the pedestrian area to the driveway areas, thanks to the use of polypropylene PP material, loaded with high resistance to loads, corresponding to specific standards (up to 400 KN/m²).

The system complies with UNI EN 17152 standards.

STANDARDS

Since in**PLUVIO** è un sistema utilizzato sotto il piano campagna, è necessario che lo stesso sia autoportante in funzione al carico per cui è destinata la superficie sovrastante.

in**PLUVIO** has been designed and manufactured with high mechanical resistance materials, and finally tested with load tests and simulations over time, so that the system itself complies with the reference standards imposed in the construction of said elements **UNI EN 17152-1:2020**, so that it can be used in different situations.

It is essential in any case, when designing a rolling system, to respect the dimensions indicated in the accompanying documents.

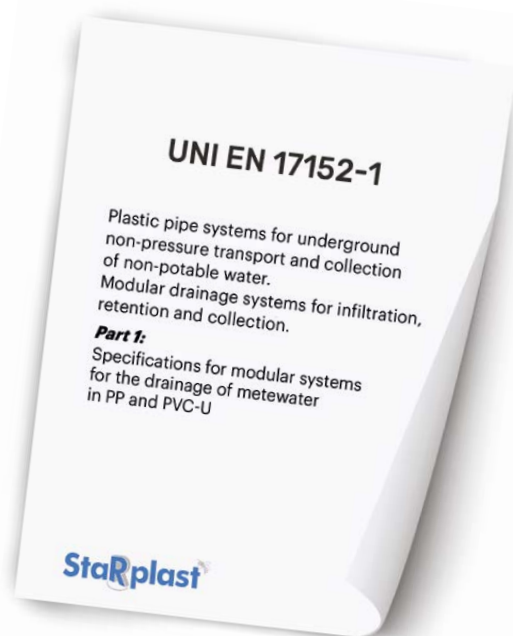

MECHANICAL RESISTANCE

One of the fundamental characteristics of drainage cell systems is the ability to create large volumes of water storage that are completely buried, while at the same time guaranteeing high mechanical resistance. This property allows the overlying surface to remain fully usable for a variety of purposes, including:

GARDENS AND GREEN AREAS
SQUARES AND PUBLIC SPACES
CAR PARKS AND VEHICULAR TRANSIT AREAS

Thanks to their modular structure and ability to withstand high loads, **drainage cell systems are an effective solution for sustainable stormwater management**, reducing the risk of flooding and improving integration with the urban context.

THE SOLUTION

RESISTANCE TO LOAD CLASSES

The **inPluvio** drainage cells provide resistance to ground and traffic stress and can be used in different load classes according to their ability to withstand specific weights, from pedestrian areas to heavy industrial vehicle loads.

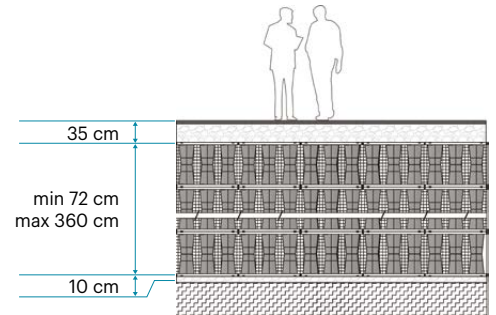

LOAD CLASSES *

Pedestrian areas, cycle paths, green zones, pavements, parking areas and parking spaces.

LEGEND

A top layer cells
grain size max. 3 mm

B inPlain drainage cells
When using the half cell, as shown in the image, it must always be positioned in the upper layer

C bottom layer
of compensation with a maximum gravel size of 3 mm

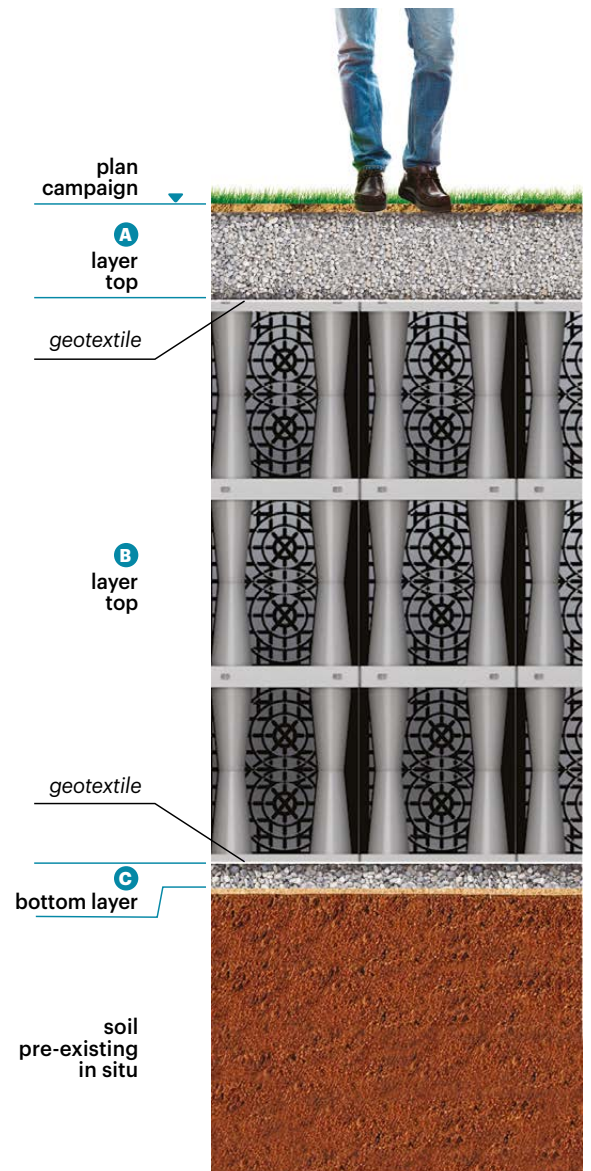

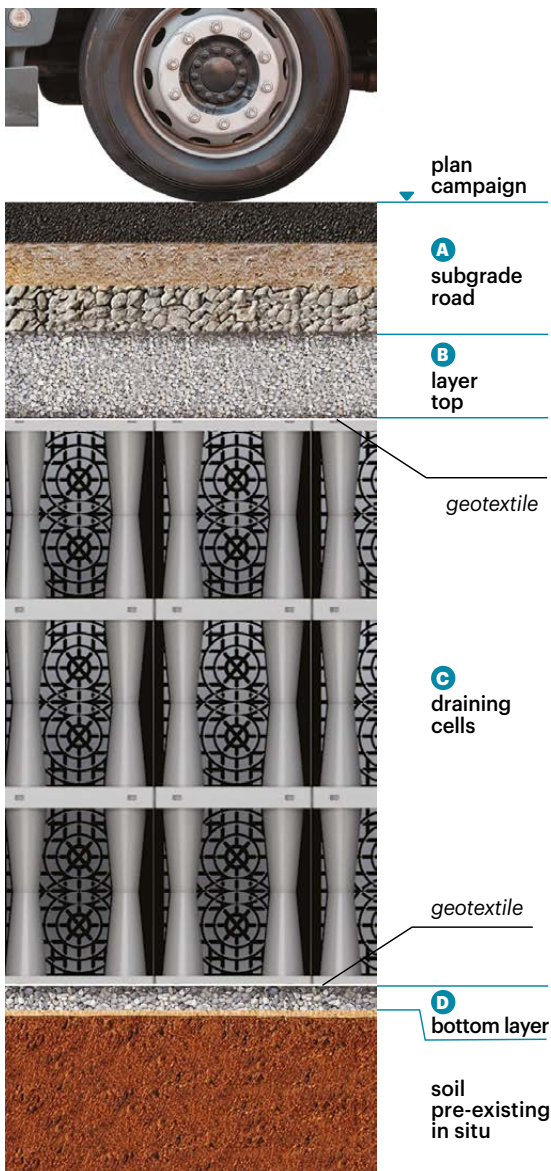
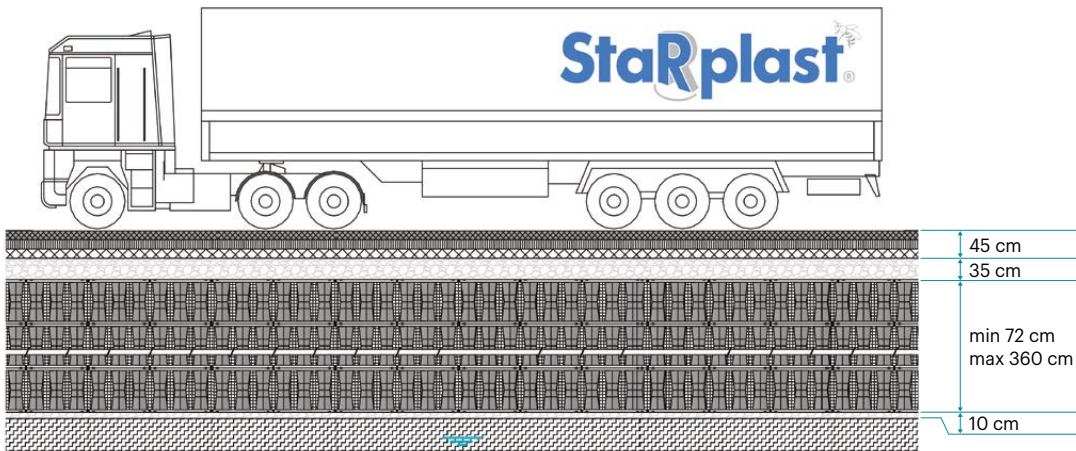

LOAD CLASSES *

- SLW30** light traffic
- SLW60** heavy traffic

LEGEND

- A** road surface
comply with regulations in force
- B** upper compensation layer
with a maximum gravel particle size of 3 mm
- A + B** its height must not be
lower than 80 cm and higher than 4m
- C** drainage cells inPluvio
when using half cells, they must always be
positioned in the upper layer
- D** lower layer
of compensation with a maximum gravel size
of 3 mm

* General information. Check with product data sheet and Starplast technical department if necessary.

APPLICATIONS

WHERE TO USE in **Pluvio** Drain Blocs

Some examples:

PARKINGS

One of the most common applications of drainage cells is the installation under car parks in shopping centres. Here, the cells **help to collect and dispose of rainwater, reducing the risk of puddles and flooding** and enabling sustainable stormwater management. This is especially important in urban areas, where impermeable surfaces can cause rapid water run-off.

In addition to being a **SUSTAINABLE** practice, drainage cells offer numerous advantages:

They collect and dispose of water, help **prevent soil erosion** and the degradation of surrounding infrastructure.

They improve water quality by filtering out meteoric impurities and they enhance spaces by making, for example, the space around a car park an evergreen and attractive area.

Drainage cells are an effective and sustainable solution for stormwater management, with applications ranging from car parks to parks, helping to create safer and more sustainable environments.



GREEN AREAS

Drainage cells **can also be used in green areas**, such as parks and public gardens.

In this context, they promote the infiltration of water into the soil, helping to keep the soil moist and supporting plant growth. **This is particularly useful in drought-prone areas**, where water management is crucial.



RESIDENTIAL AREAS

Other applications include **residential areas**, where they can be installed under driveways and patios to improve rainwater management. Even in sports facilities, such as football pitches or cycle paths, drainage cells can provide a dry and safe surface, reducing the risk of flooding.



COMPOSITION

ELEMENTS

When ordering in**PLUVIO** it should be fundamental being acknowledged about the final design solution with the purpose of placing all the elements in the right position during the delivery. Please contact our Technical Department to be advised on the right solution.

INP Y 10060 MZCC-C
half-cell



INP Y 10060 MZCP-C
half cell with
inspection hole



INP Y 00707 GIUC-C
coupling joint



INP Y 00703 MZGI-C
half coupling



INP Y 3322 CONM-C
male cone
for half cell



INP Y 3322 CONF-C
female cone
for half cell



INP Y 10072 PAFL-C
long side wall



INP Y 06072 PAFC-C
wall short side



INP Y 10043 MPFL-C
half-wall
long side



INP Y 06043 MPFC-C
half-wall
short side



INP Y 00717 TPCC-C
closure cap
cell hole



ASSEMBLED

The system is easy to assemble on site without the use of mechanical means, as its elements can be handled by a single person. The connections between the individual elements and the side walls are easy and intuitive.

INP Y 10060 MZCC-C + INP Y 10060 MZCC-C

Complete cell module



INP Y 10060 MZCC-C + INP Y 10060 MZCP-C

Complete cell module for inspection base



INP Y 10060 MZCP-C + INP Y 10060 MZCP-C

Complete cell module for inspection channel



INP Y 10060 MZCC-C + n.3 INP Y 3322 CONM-C + n.3 INP Y 3322 CONF-C + n.6 INP Y 00717 TPCC-C

Half-cell module



COMPOSITION

ASSEMBLY

Mounting example:

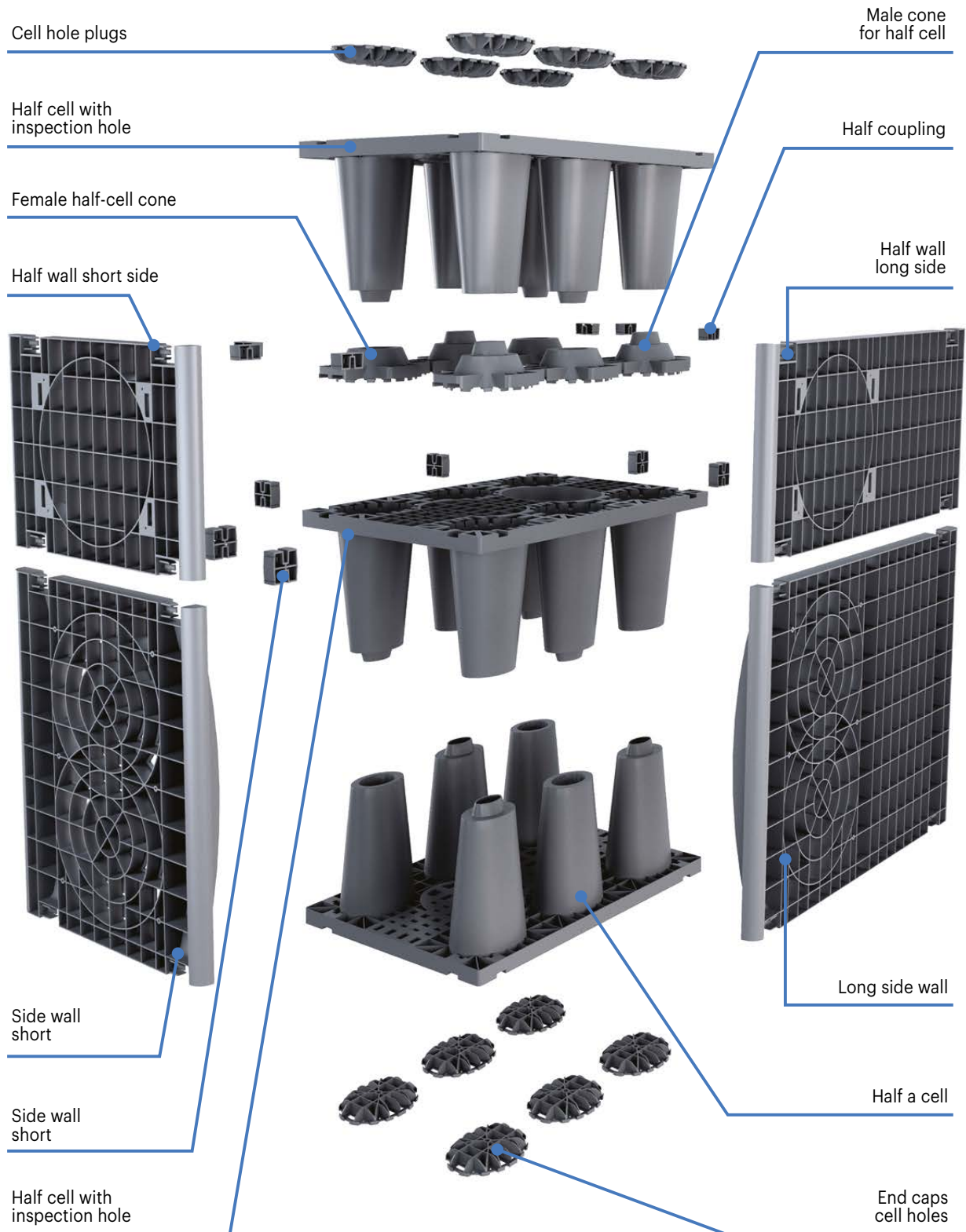

DETAILS THAT MAKE THE DIFFERENCE



COMPOSITION

ACCESSORIES TO COMPLETE THE SYSTEM

The **inPLUVIO** system offers the possibility of using a whole series of specific dedicated components, such as water inlet and outlet manifolds, inspection inlets, geotextile and geomembrane, to accompany the drainage basin in order to facilitate the construction of the finished work, including its connections to the pipes.

COL X 6340 CLDE

Line collector
with shunt 630



COL X 5040 CLDE

Line collector
with shunt 500



COL X 4040 CLDE

Line collector
with shunt 400



COL X 4030 ISCA

Inspection port
chimneys Ø400 h 300



COL X 4040 PZIS

Inspection pit for
containment stainless
steel grid



COL X 4070 ISCA

Inspection port
chimneys Ø400 h 700



COL X 4025 RING

Inspection pit
for containment
stainless steel grid



COL Y 0060 GRIX

Stainless steel grid for
inspection pit



COL X 4025 CURV

Reduction bend 90°
400/250



COL X 3525 INTE

Telescopic inlet socket
350/315/250



Accessories for system with geomembrane

inlet/outlet manifolds integrated with 5 mm thick HDPE sheet 1000x1000 for use in the geomembrane-wrapped basin system.

INP COL X 4025 RING-C

Inspectable inlet distribution manifold h 250 with welded geomembrane sheet



INP COL X 4030 ISCA

Inspection port chimneys Ø400 h 300 with sheet of welded geomembrane



INP COL X 4025 CURV

90° reduction bend 400/250 with welded geomembrane sheet



INP COL X 4070 ISCA

Inspection port chimneys Ø400 h 700 with sheet of welded geomembrane



INP Y 0300 TNT

Geotextile tnt



INP Y 2500 GMB

Geomembrane HDPE



CHAPTER ITEM

Supply of a drainage or stormwater storage system for burying, **inPluvio** type, with single stackable elements (half-cells), made of PP Polypropylene plastic material filled with high mechanical resistance, with empty-full volume ratio of 96%.

The single element, made up of elliptical truncated cones with male-female coupling, forms the cell module and must comply with the following mechanical characteristics: crush strength 400 KN/m² and lateral load resistance of 100 KN/m², in accordance with UNI EN 17152-1 standards.

The cell module shall comply with the following dimensions: Lu1000 x La600 x h720 mm equal to a volume of 0.42m³ and a minimum lateral distance between coupling cones of 250 mm, to facilitate the passage of the hydrant.

The cell modules, assembled together by means of specific hooks and suitable reinforcing side walls, shall be

- in the water drainage system wrapped with 100 g/m² TNT geotextile
- for the cell system used as storage, they shall be wrapped with 100 g/m² geotextile TNT, 2.5 mm HDPE geomembrane and again with 100 g/m² geotextile TNT

On the upper part of the basin, inspection ports will be provided at the cells with holes, channelled to the base of the system.

These will be positioned on the ends of the two opposing sides (600 mm cell side), 1 every 3 modules alternating with each other, in order to guarantee a passage in lines perpendicular to the basin, for correct system maintenance.

The water conveyance pipes must be connected to specific manifolds for correct distribution of the water in the various points of the basin and equipped with grids to separate coarse bodies and plastics.

Total size of the drainage basin: Volume m³

Surface area: Le m..... x W m.....

Height: h m

Price: €/m³

PRICE LIST

model	description	Le x W x h mm	€
-------	-------------	------------------	---

POLYPROPYLENE PP SYSTEM COMPONENTS

INP Y 10060 MZCC-C	Half-cell closed	1000 x 600 x 390	38,90
INP Y 10060 MZCP-C	Half-cell with inspection hole	1000 x 600 x 390	38,90
INP Y 00707 GIUC-C	Coupling joint	72 x 70 x 33	0,53
INP Y 00703 MZGI-C	Half coupling	72 x 35 x 33	0,43
INP Y 00717 TPCC-C	Cell closing cone cap	72 x 175 x 33	2,25
INP Y 03322 CONM-C	Male cone for half-cell	333 x 220 x 100	3,70
INP Y 03322 CONF-C	Female cone for half-cell	333 x 220 x 100	3,65
INP Y 10072 PAFL-C	Long side wall	1000 x 720 x 82	28,00
INP Y 06072 PAFC-C	Short side wall	600 x 720 x 82	19,40
INP Y 10043 MPFL-C	Half-wall long side	1000 x 430 x 36	18,50
INP Y 06043 MPFC-C	Half-wall short side	600 x 430 x 36	12,90

ACCESSORIES TO COMPLETE THE SYSTEM

COL X 6340 CLDE	Line collector with 630 mm extension	Ø 630/400/500	1.080,00
COL X 5040 CLDE	Line collector with 500 mm take-off	Ø 500/400/400	880,00
COL X 4040 CLDE	Line collector with extension 400 mm	Ø 400/400/400	520,00
COL X 4030 ISCA	Chimney breast Ø400	Ø 400/250 h 300	125,00
COL X 4070 ISCA	Flue pipe inspection opening Ø400	Ø 400/250 h 700	195,00
COL X 4040 PZIS	Inspection shaft for stainless steel grid containment	Ø 400/400/355	580,00
COL Y 0060 GRIX	Stainless steel grid for retaining solids for sump	Ø 600	590,00
COL X 4025 RING	Inspectable inlet distribution manifold	Ø 400/250/250 h 250	505,00
COL X 3525 INTE	Telescopic inlet socket	Ø 350/315/250	105,00
COL X 4025 CURV	90° reduction bend	Ø 400/250	95,00
INP COL X 4025 RING	col x 4025 ring + welded HDPE sheet 100x100 mm		655,00
INP COL X 4030 ISCA	col x 4030 isca + welded HDPE sheet 100x100 mm		280,00
INP COL X 4070 ISCA	col x 4070 isca + welded HDPE sheet 100x100 mm		330,00
INP COL X 4025 CURV	col x 4025 curv + HDPE welded sheet 100x100 mm		245,00
INP Y 0300 TNT	Geotextile 500 gr/m ²		13,00 x m ²
INP Y 2500 GMB	HDPE geomembrane 2.5 mm thick (including laying)		42,00 x m ²
INP POSA	Laying of inPluvio system only m ³		21,00 x m ³

SERVICES AND MAINTENANCE

INP VIP	Video inspection		on request
INP IDR	Adjustable hydrant		on request
INP MON	On-site cell assembly		on request
INP MAP	Scheduled maintenance		on request

LAYING

NB: the laying of the cells and the covering, especially of the geomembrane, must be entrusted to highly specialised personnel. **Starplast assumes no responsibility for any damage, accidents or injuries that may occur inside the site, resulting from negligence, failure to comply with safety regulations or from causes not directly attributable to its own conduct. Every activity carried out within the area is under the full responsibility of the safety officers and operators involved.**

FOR DRAINAGE AND STORAGE SYSTEM

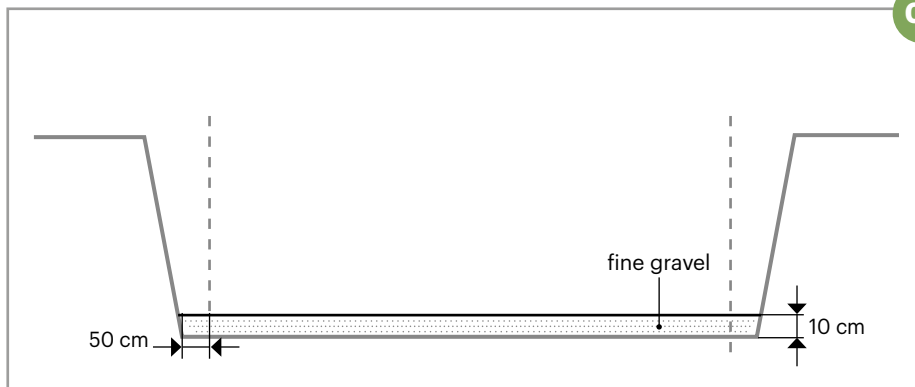

DIG THE GROUND

planning to leave a distance between the system and the walls of at least 50 cm. The excavation must be stable and therefore safe for the workers. Create a 10 cm layer with fine gravel max. 3 mm, compacted and levelled, which ensures permeability for the system.

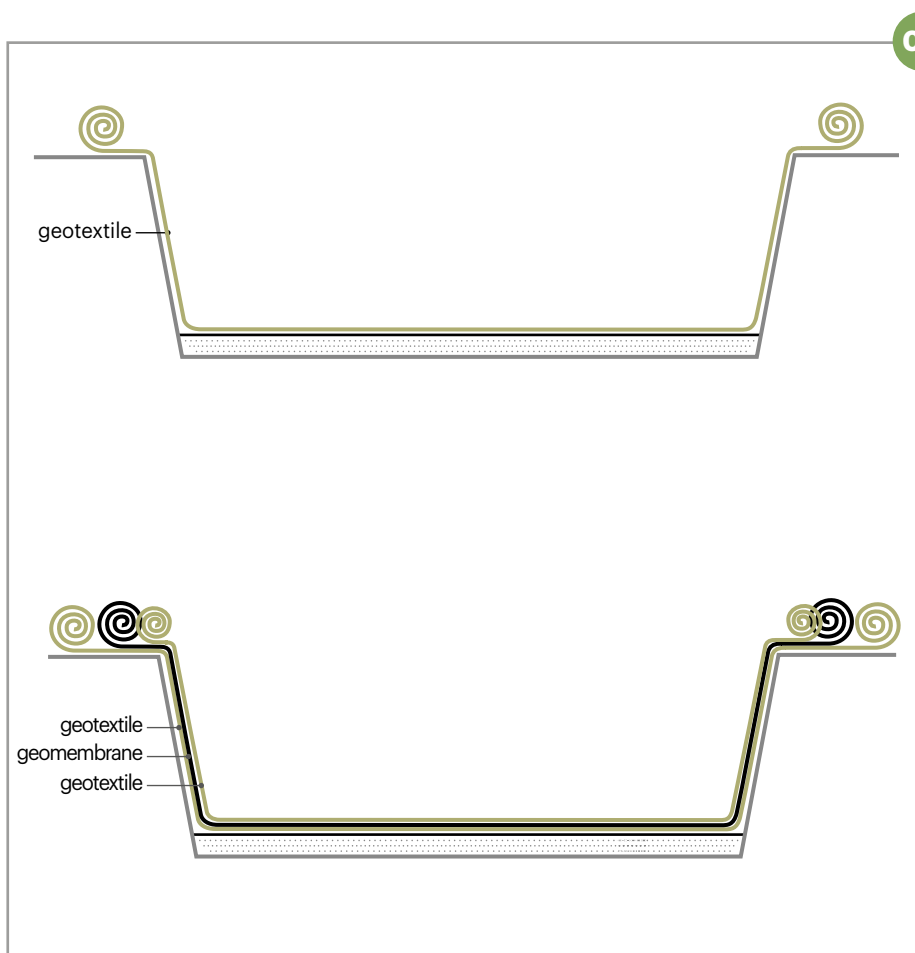

LAY TNT GEOTEXTILE SHEET

100 g/m² in such a quantity that it can completely envelop the system. Overlap the side strips by at least 50 cm to prevent the backfill material from penetrating the system.

In storage systems where the basin is to be wrapped with HDPE geomembrane, it should be protected both outside and inside with 500 g/m² TNT. Then in order we lay TNT / geomembrane / TNT

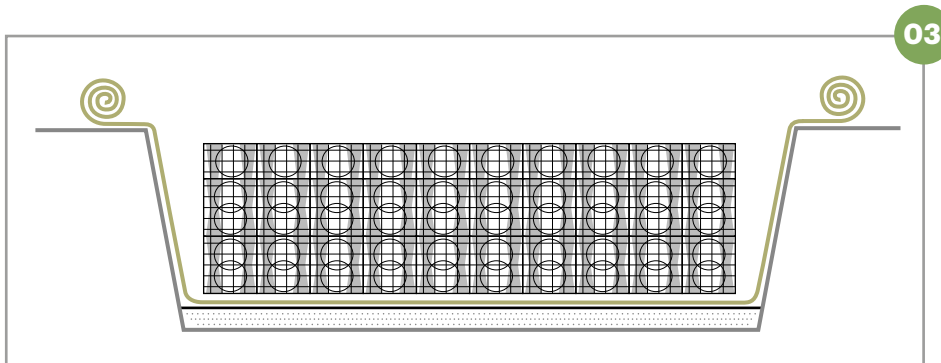

03

PLACE THE KIT INPLUVIO

(for assembly see diagram page 22).

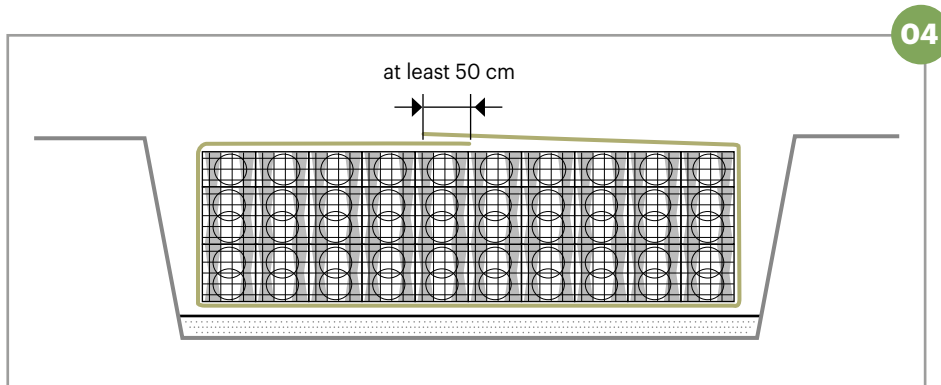

04

Wrap the entire system completely with the TNT geotextile sheet, overlapping it by 50 cm, to prevent the backfill material from penetrating the system.

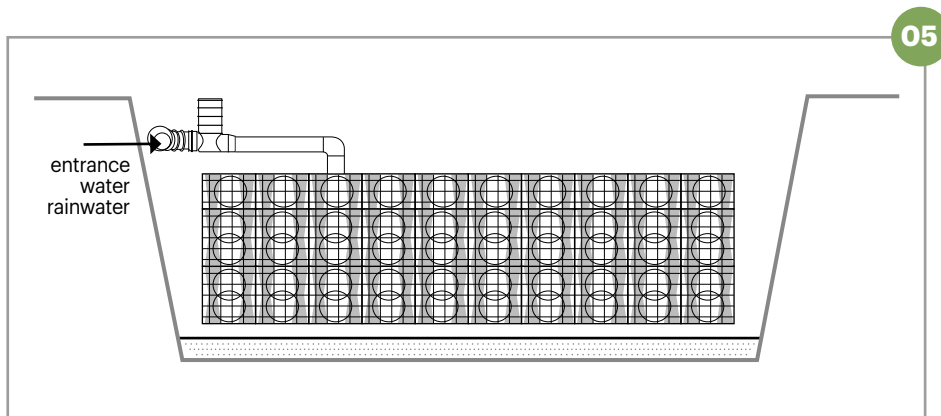

05

CONNECT THE COLLECTORS

stormwater inlet manifolds according the existing diameters. At the collector inlets, cut the TNT to obtain a free passage.

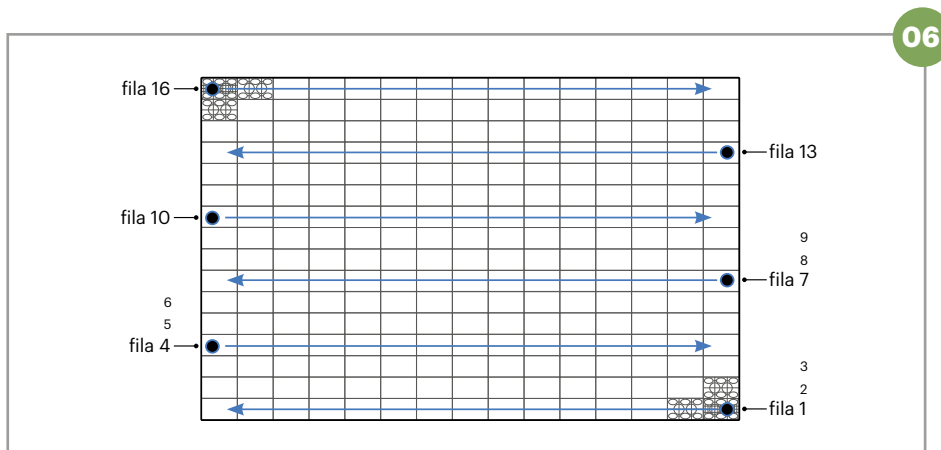

06

POSITIONING INSPECTION PORTS

In order to ensure a better inspection and cleaning of the system, it is recommended to position the inspection wells no. 1 every 3 rows in an opposing manner (see diagram to the side).

LAYING

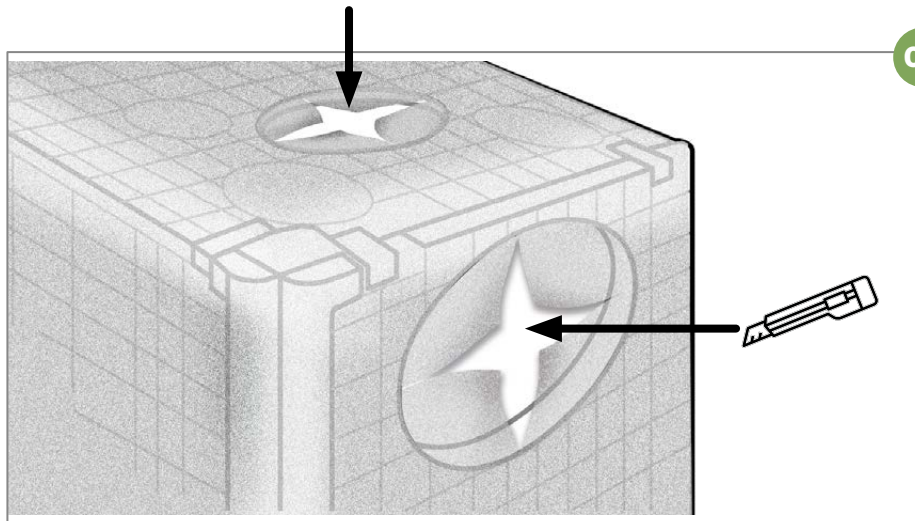

07

TNT ONLY

Drill the layers where the pipes and manholes will be inserted. Cut the TNT crosswise and fold the flaps inwards for the insertion of the collectors.

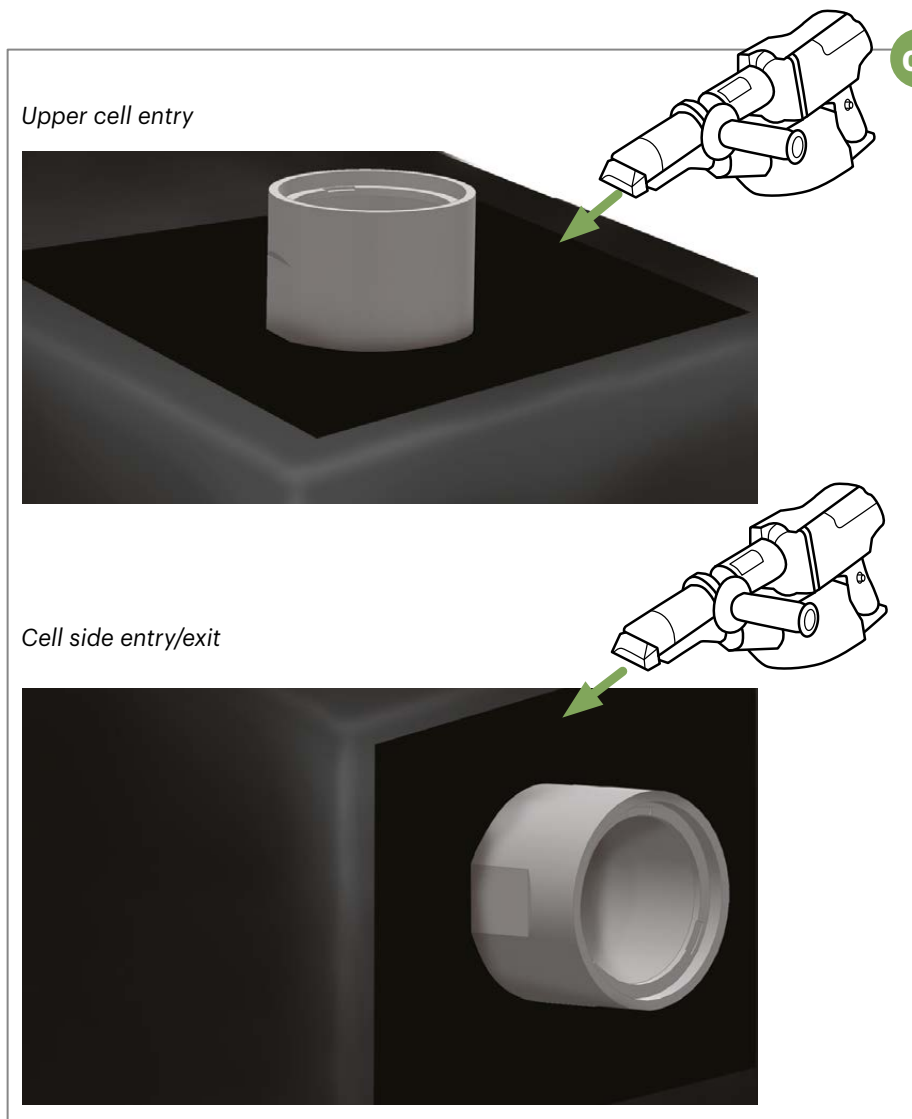

08

WITH GEOMEMBRANE

In the case of an accumulation system

- Wrap the basin completely with a first layer of 500g/m² TNT geotextile.

- Completely cover with 2.5 mm HDPE geomembrane welded with a special track on all sides, marking with a white felt-tip pen where the collectors/inspection ports will be positioned and cut the HDPE layer with a cutter at the holes for the insertion of the collectors.

- Insert the integrated HDPE sheet collectors and weld them to the geomembrane

08.1

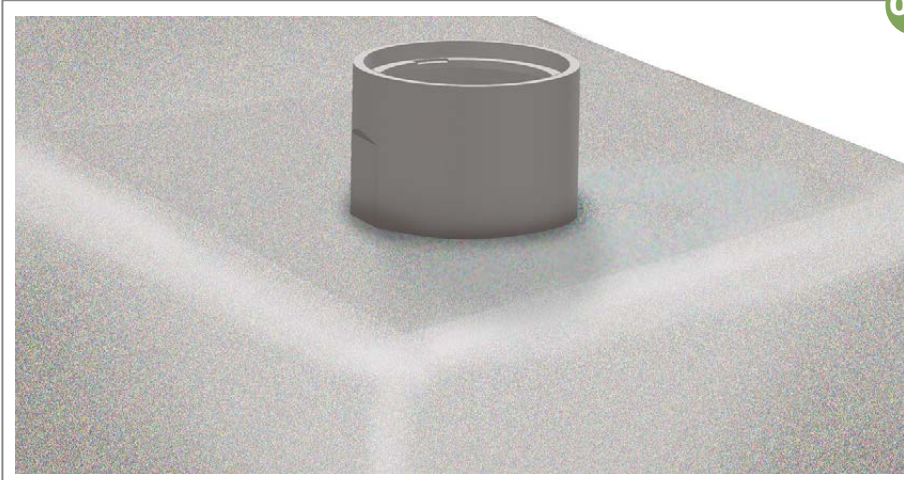

FINAL WRAPPING

Complete with an outer layer of geotextile TNT 500 g/m²

09

MANIFOLD POSITION INPUT:

Top entry solution

Position the inlet pipes in the upper part of the system, the inspection ports and any calibrated outlet at the bottom. If no pre-treatment, it is advisable to always insert the grid-holder manifold, in order to block the entrance of coarse bodies and plastics, as these can hardly be removed during the cleaning operations of the drainage system.

NB: when using grid collectors, we recommend the positioning of at least 2 of them, in order to guarantee the entry of water even if one collector is obstructed.

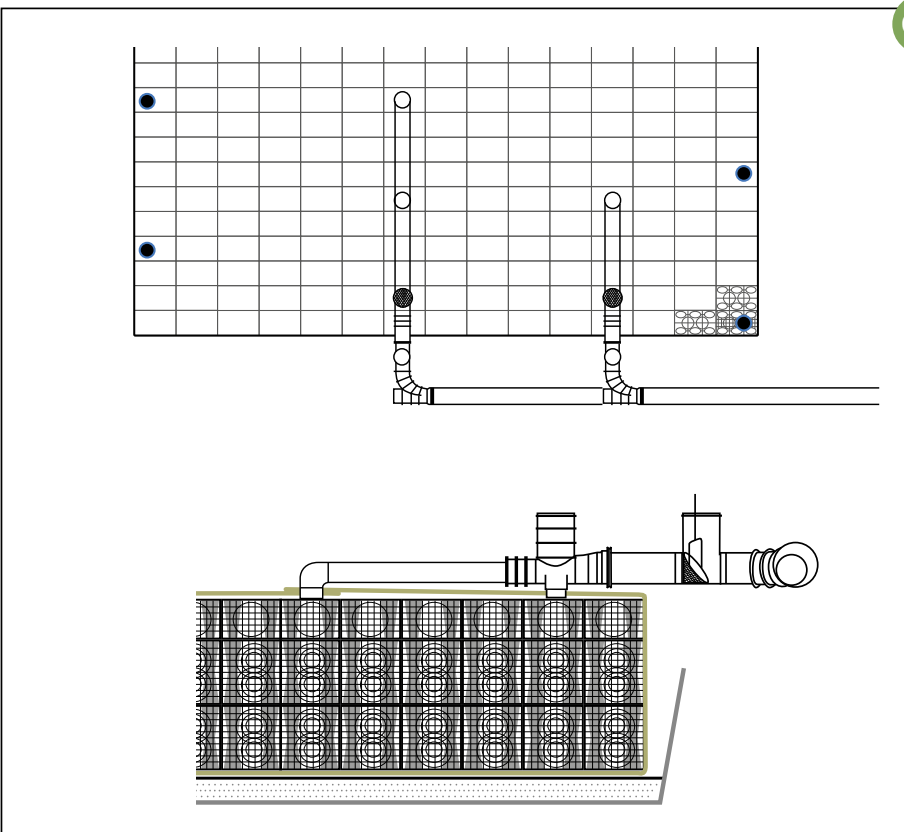

LAYING

09.1

MANIFOLD POSITION INLET:

Side inlet solution

Position the inlet and outlet pipes in the vertical wall.

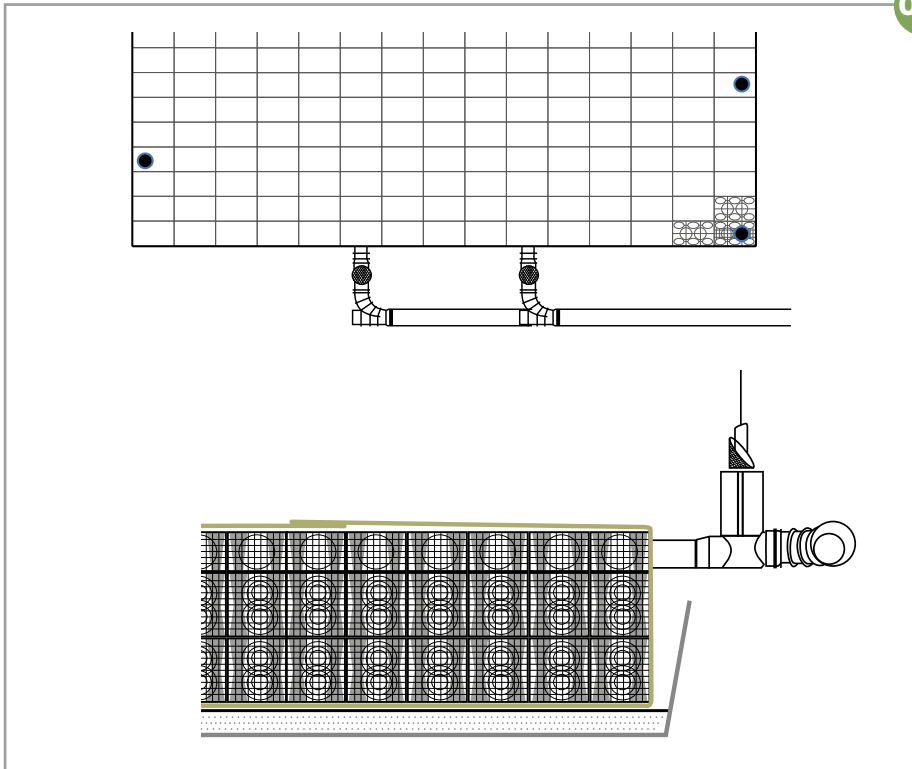

10

LATERAL BACKFILL

Use suitable trench backfill material with a maximum grain size of 3 mm. We recommend facilitating compaction with water jets (**do not use frozen earth or frozen material**).

The backfill should be evenly distributed on all sides and compacted in layers of maximum 30 cm, using medium-light soil compaction equipment, such as vibratory plates or vibratory rammers. During backfilling, ensure that the geotextile remains in place and that **inPluvium** is not damaged.

The backfill material must guarantee a permeability at least equal to that of the laying soil.

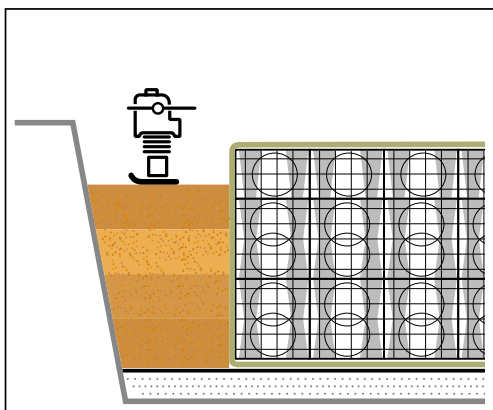
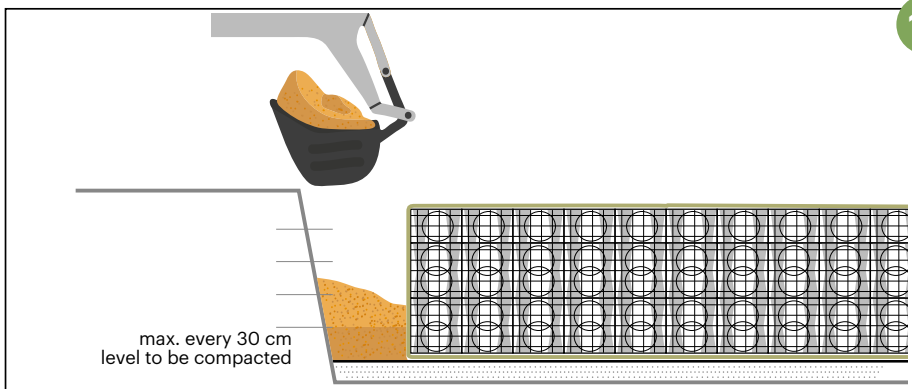

IT IS NOT PERMITTED to carry out the compaction phase using vibratory road rollers or percussive compaction equipment.

11

FIRST COVERING LAYER

This can be done with a small excavator.
For the passage of wheel loaders or wheeled excavators with a maximum weight of 15 t (tracked, four-wheeled or with double tyres), a compacted covering of at least 30 cm above the plant is required.
The passage of heavy construction vehicles (up to 50 kN per wheel) is only permitted after a compacted covering of at least 60 cm thickness.
When tipping the covering materials, ensure that the above load limit is not exceeded.

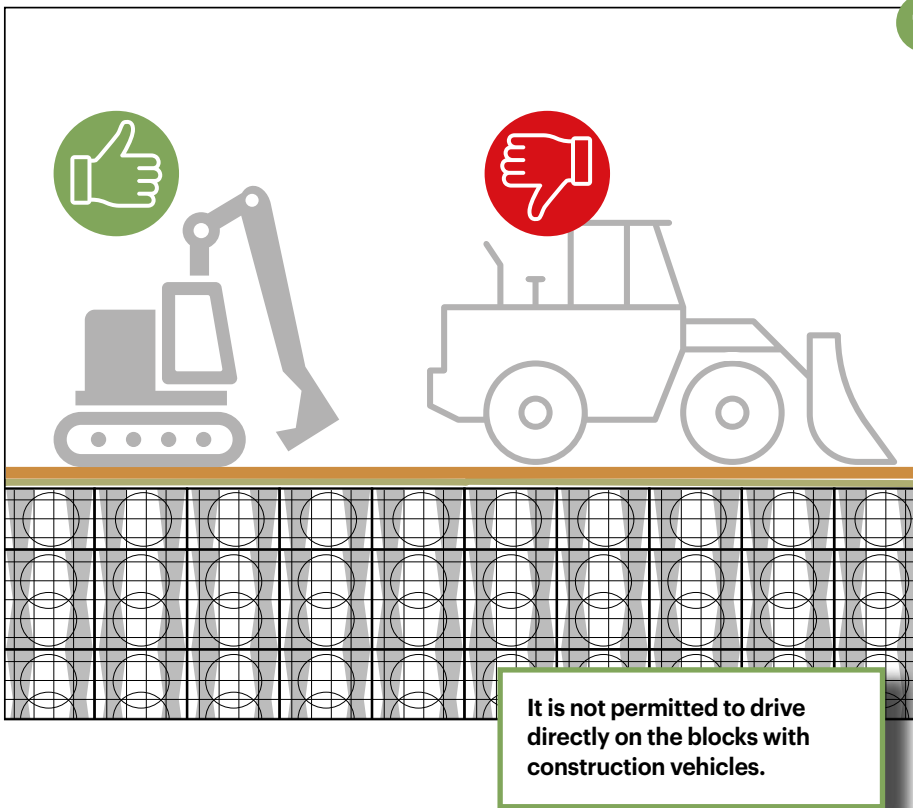

It is not permitted to drive directly on the blocks with construction vehicles.

12

CONSTRUCTION OF THE COVER LAYERS

Cover the trench body according to the data on pages 16 and 17, depending on the load class (SLW30/SLW60).

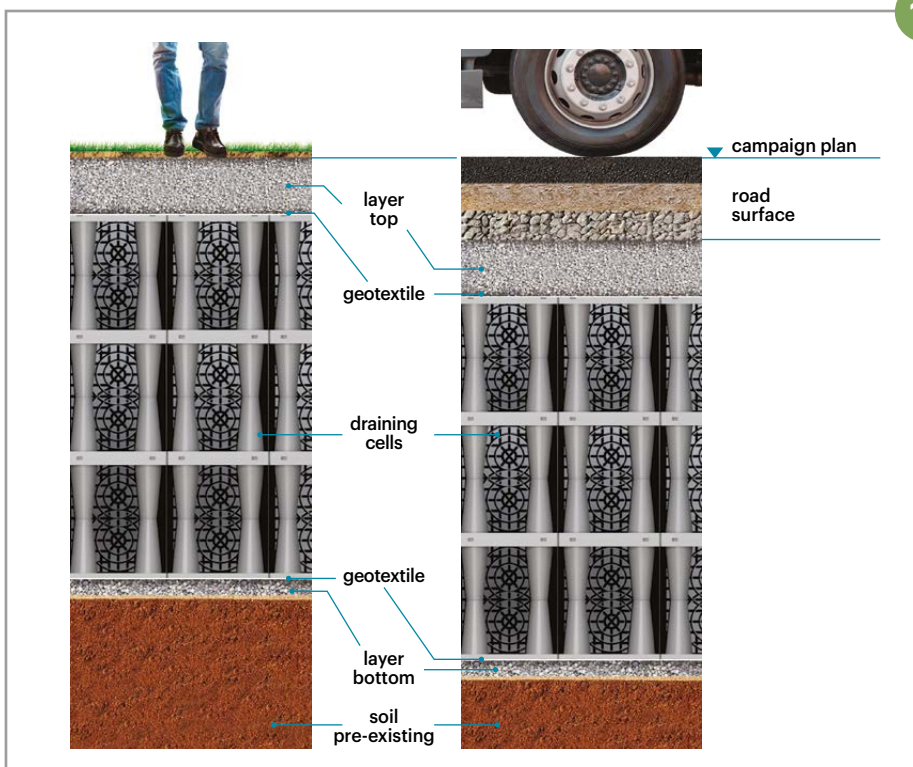



Starplast[®]

 +39 0722 079201

 info@starplastsrl.it
www.starplastsrl.it

   **Starplast srl**

 Via dell'Artigianato, 43 / 61028
Sassocorvaro Auditore (PU)

